

STANDARD 4" ROUND OR SQUARE PANCAKE BOX WITH HANGAR BAR. USE PROPER ANCHOR BOLTS/LAG BOLTS TO SECURE.

110/120 V RUN

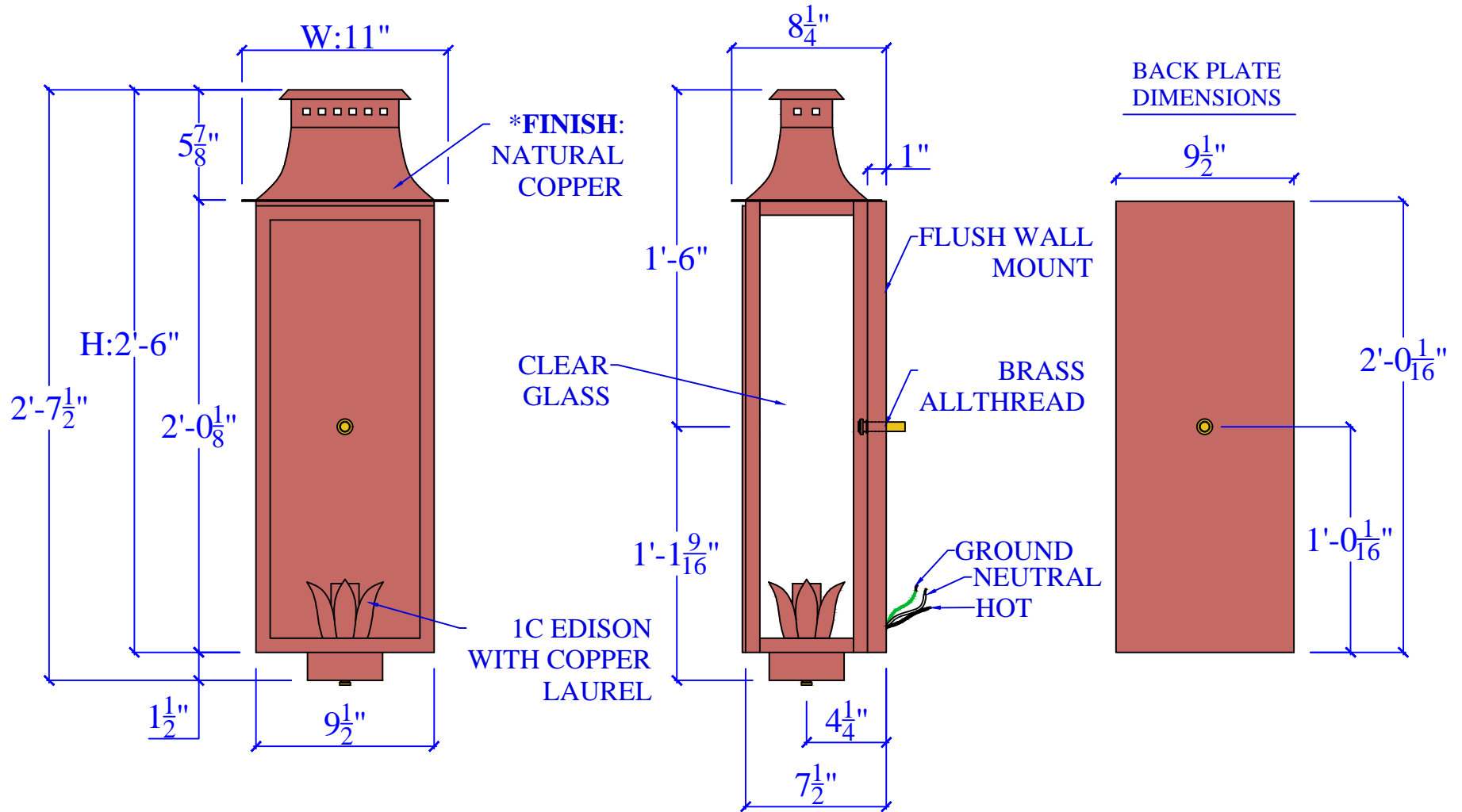

**JOHNSTONE BAY, INC. (JB)**

1800 EAST I-65 SERVICE RD. N. PHONE: (251) 478-0072 FAX: (251) 471-5945 MOBILE, ALABAMA 36617  
 WWW.CHARLESTONLIGHTING.COM WWW.FAUBOURGLIGHTING.COM WWW.CHARLESTONGASLIGHT.COM

**SPECIFICATION SHEET**

COPYRIGHT 1994 TO CURRENT YEAR, JOHNSTONE BAY, INC. (JB) ALL DESIGNS, DRAWINGS, MODEL NUMBERS, AND LANTERN DESIGNATIONS ARE THE SOLE AND EXCLUSIVE PROPERTY OF (JB) AND SHALL NOT BE DUPLICATED IN WHOLE OR PART WITHOUT THE WRITTEN CONSENT OF (JB).

LIGHT:	TRAN - H30" W11" - 1C (LAUREL)	DATE:	APP.BY:	J.D.
BRACKET:	FLUSH WALL MOUNT		REV.	